



AND050VL-LED

640 x 480 Pixels LCD Color Monitor

The AND050VL-LED is a compact full color TFT LCD module, whose driving board is capable of converting composite video signals to the proper interface of LCD panel and is suitable for computer peripheral, industrial meter, image communication and multi media.

This device consists of an amorphous silicon panel with back-light, incorporating a TFT-array that has 640 x 480 pixels on a 5 inch diagonal screen, with pixel in stripe configuration, 262,144 display colors and a LVDS transmission interface.

Features

- VGA (640 x 480 pixels) resolution
- Amorphous silicon TFT LCD panel with LED back-light
- Pixel in stripe configuration
- Light weight and slim
- Displays 262,144 colors
- Optimum Viewing Direction: 6 o'clock
- Image Reversion: Up/Down & Left/Right
- Supports the DENB mode, Sync mode (Hsync+Vsync)
- LVDS transmission interface
- **RoHS Compliant**

Mechanical Characteristics

Parameter	Specification	Unit
Screen Size	5.0 (diagonal)	inch
Display Format	640 (H) x (R, G, B) x 480(V)	dot
Display Colors	262,144	
Active Area	101.76 (H) x 74.88 (V)	mm
Pixel Pitch	0.159 (H) x 0.156 (V)	mm
Pixel Configuration	Stripe	
Outline Dimension	120.7 (H) x 92.8 (V) x 12.5 (D)	mm
Weight	173.6 ± 10	g
Back-light	24-LED	
Display Mode / Surface	Normally white / Anti-glare & SWV film	

Recommended Driving Condition for LED Back Light

GND= 0V Ta=25°C

Parameter	Symbol	Specifications			Unit	Remark
		Min.	Typ.	Max.		
Supply Voltage of LED Backlight	V_{LED}	–	11.0	11.5	V	$I_L=20mA$
Supply Current of LED Backlight	I_{LED}	–	20	–	mA	Note 1
Backlight Power Consumption	P_{LED}	–	1.76	1.84	W	Note 2

Note 1: The LED driving condition is defined for each LED module. (3 LED Serial)

Note 2: $P_{LED} = V_{LED1} * I_{LED1} + V_{LED2} * I_{LED2} \dots + V_{LED7} * I_{LED7} + V_{LED8} * I_{LED8}$

Product specifications contained herein may be changed without prior notice. It is therefore advisable to contact Purdy Electronics before proceeding with the design of equipment incorporating this product.

Electrical Characteristics: Recommended Operating Conditions GND=0V, Ta=25°C

Item	Symbol	Specifications			Unit	Remark
		Min.	Typ.	Max.		
Supply Voltage	V _{CC}	3.0	3.3	3.6	V	
Current Dissipation	I _{CC}	–	77.90	–	mA	Note 1
LVDS Differential Input High Threshold	V _{TH}	–	–	100	mV	Note 2
LVDS Differential Input Low Threshold	V _{TL}	-100	–	–		Note 2
V _{oom} Voltage	V _{ccm}	–	2.7	–	V	

Note 7-1 : To test the current dissipation of VCC using the "color bars" testing pattern shown as below

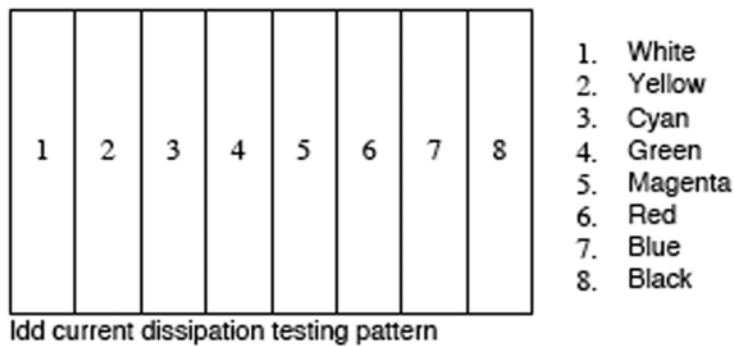

Note7-2 : Please refers to THC63LVDF64A specification by THINE Corporation.
This LCD module conforms to LVDS standard.

Absolute Maximum Ratings*: GND=0V, Ta=25°C

Parameters	Symbol	Min.	Max.	Unit	Remark
Supply Voltage	V _{CC}	-0.3	+7.0	V	
Input Signals Voltage	V _{sig}	-0.3	V _{CC} +0.3	V	Note 1

* The above are maximum values, which if exceeded, may cause faulty operation or damage to the unit.

Note 1: Input signals include CLK, Hsync, Vsync, DENB, R[0:5], G[0:5] and B[0:5].

Optical Characteristics Ta = 25°C

Parameter	Symbol	Conditions	Specifications			Unit
			Min.	Typ.	Max.	
Viewing Angle	Horizontal	$\theta = 21, 22$	± 55	± 60		deg
	Vertical	$\theta = 12$	30	40	-	
		$\theta = 11$	50	55	-	
Contrast Ratio	CR	at optimized viewing angle	200	400	-	-
Response Time	Rise	Tr	-	15	30	ms
	Fall	Tf	-	25	50	
Brightness	L	$\theta = 0^\circ$	400	450	-	cd/m2
Luminance Uniformity	U		70	80	-	%
LED Life Time		+25°C	20,000	30,000	-	hr
White Chromaticity	x	$\theta = 0^\circ$	0.28	0.31	0.34	-
	y		0.31	0.34	0.37	
Cross Talk		$\theta = 0^\circ$	-	-	3.5	%

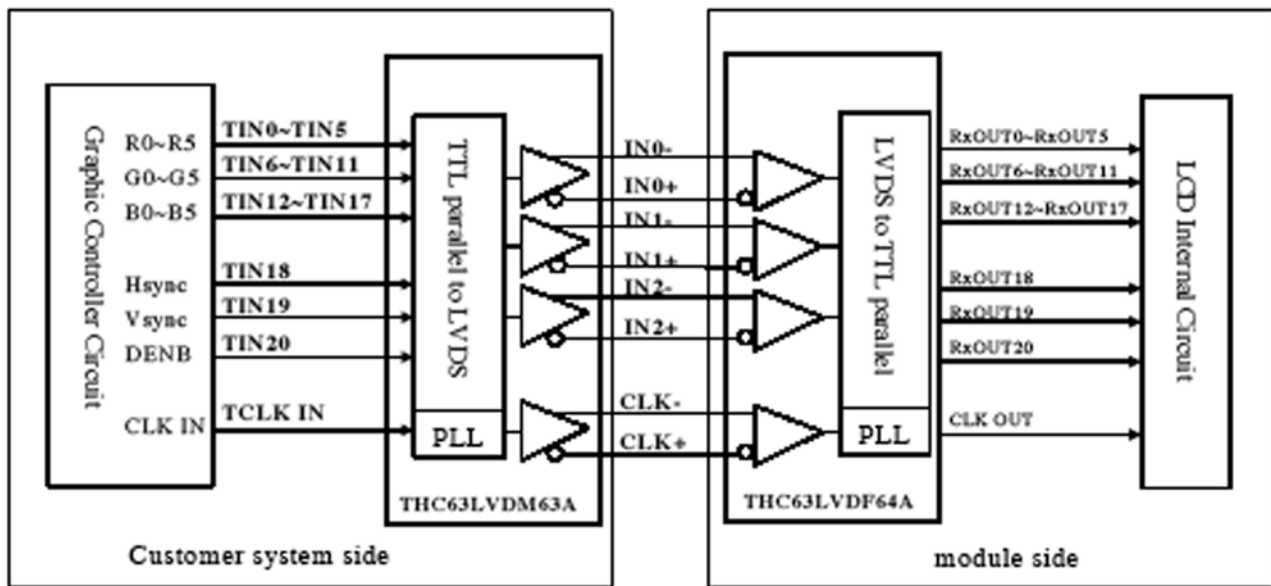
LVDS Interface Block Diagram

Input Terminals:

TFT-LCD Panel Driving

Connector Type: DFL19K-20P-1H(HRS)

Pin #.	Symbol	Function
1	Vcc	+3.3V Power Supply
2	Vcc	+3.3V Power Supply
3	GND	Ground
4	GND	Ground
5	IN0-	LVDS receiver signal channel 0
6	IN0+	LVDS receiver signal channel 0
7	GND	Ground
8	IN1-	LVDS receiver signal channel 1
9	IN1+	LVDS receiver signal channel 1
10	GND	Ground
11	IN2-	LVDS receiver signal channel 2
12	IN2+	LVDS receiver signal channel 2
13	GND	Ground
14	CLK-	LVDS receiver signal clock
15	CLK+	LVDS receiver signal clock
16	GND	Ground
17	NC	No Connection
18	NC	No Connection
19	GND	Ground
20	GND	Ground

Backlight Driving

Connector Type: JST BHSR-02VS-1, Pin No 2-pin

Pin No.	Symbol	Description	Remarks
1	+	Input terminal (Positive electrode side)	Wire color: Red
2	-	Input terminal (Ground side)	Wire color: Black

Pixel Arrangement - The LCD module pixel arrangement is stripe.

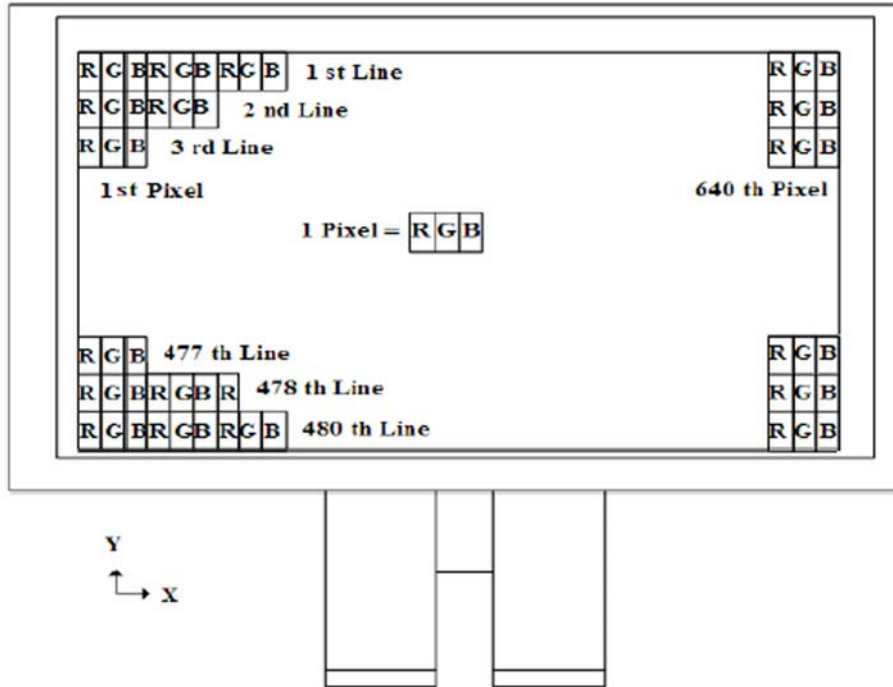

Block Diagram - TFT-module Block Diagram.

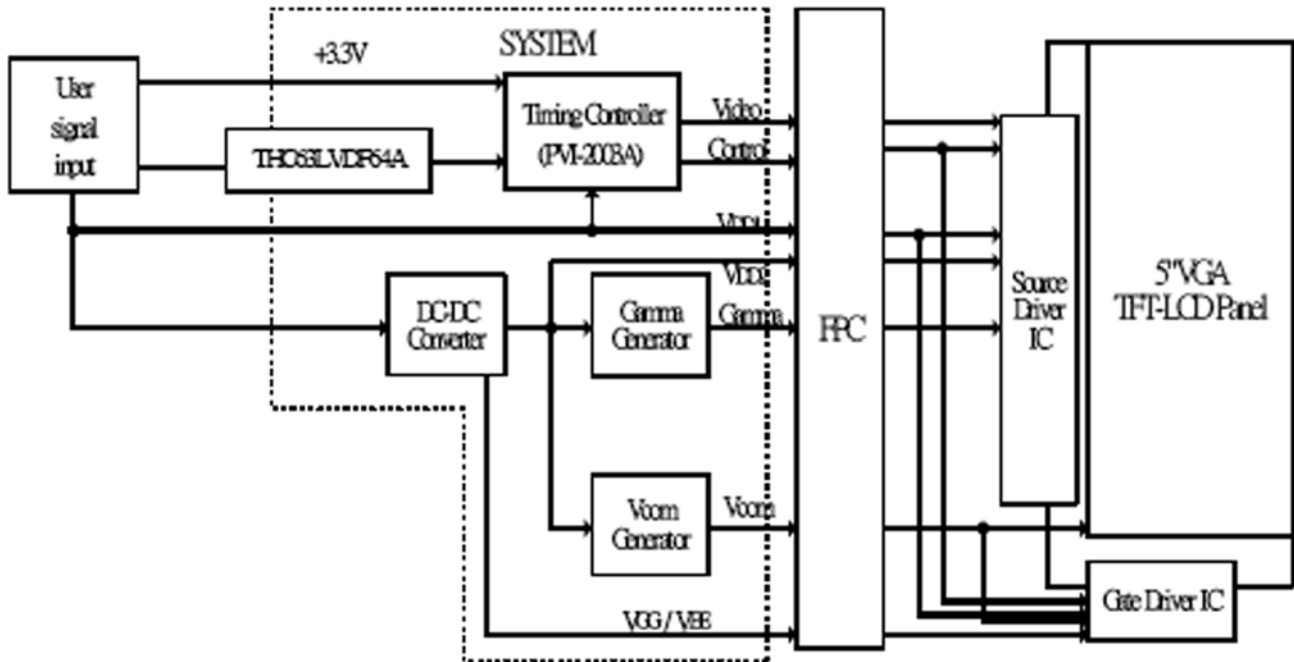

Interface Timing: Timing Parameters

Item		Symbol	Min.	Typ.	Max.	Unit
Power Supply		VCC	3.0	3.3	3.6	V
CLK	Frequency	1/tc	–	25	–	MHz
		tc	–	40	–	ns
HSYNC	Period	Hp	–	32	–	us
			–	800	–	tc
	Display period	Hdp	–	640	–	tc
	Pulse width	Hpw	–	96	–	tc
	Back-porch	Hbp	–	46	–	tc
	Front-porch	Hfp	–	18	–	tc
	Hpw+Hbp	–	–	142	–	tc
	Hsync-CLK	Hhc	10	–	Tc-10	ns
Vsync-Hsync	Hvh	0	0	200	tc	
VSYNC	Period	Vp	–	16.8	–	ms
			–	525	–	Hp
	Display period	Vdp	–	480	–	Hp
	Pulse width	Vpw	–	2	–	Hp
	Back-porch	Vbp	–	33	–	Hp
	Front-porch	Vfp	–	10	–	Hp
Vpw + Vbp	–	–	35	–	Hp	
DENB	Horizontal scanning period	T1	–	800	–	tc
	Horizontal display period	T2	–	640	–	tc
	Vertical display period	T3	–	480	–	T1
	Frame cycling period	T4	520	525	800	T1
R, G, B	CLK-DATA	Dcd	10	–	–	ns
	DATA-CLK	Ddc	8	–	–	ns

Mechanical Drawing of TFT-LCD Module

Outline Drawing : Front View (unit mm)

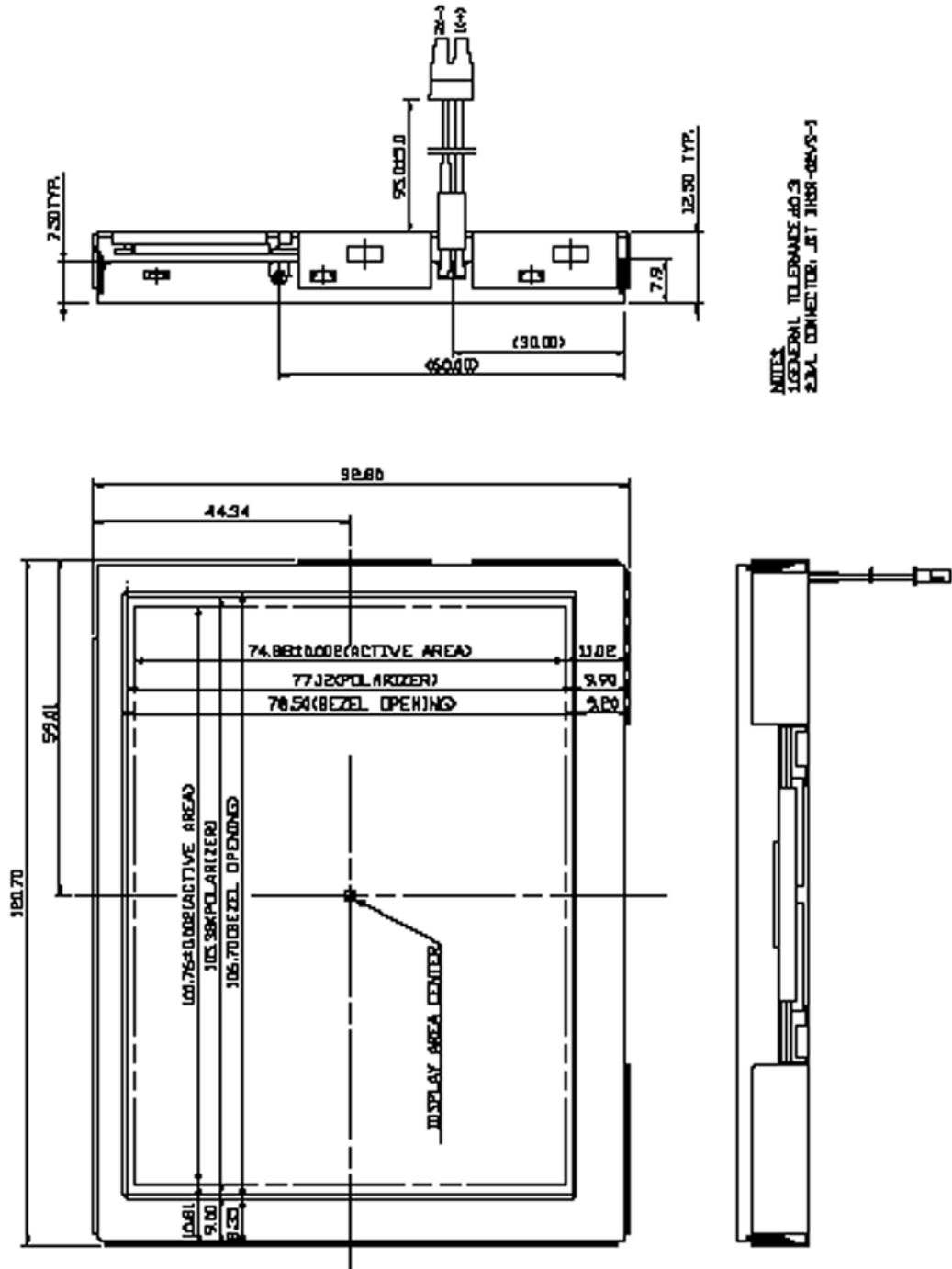

Outline drawing : Rear View (unit mm)

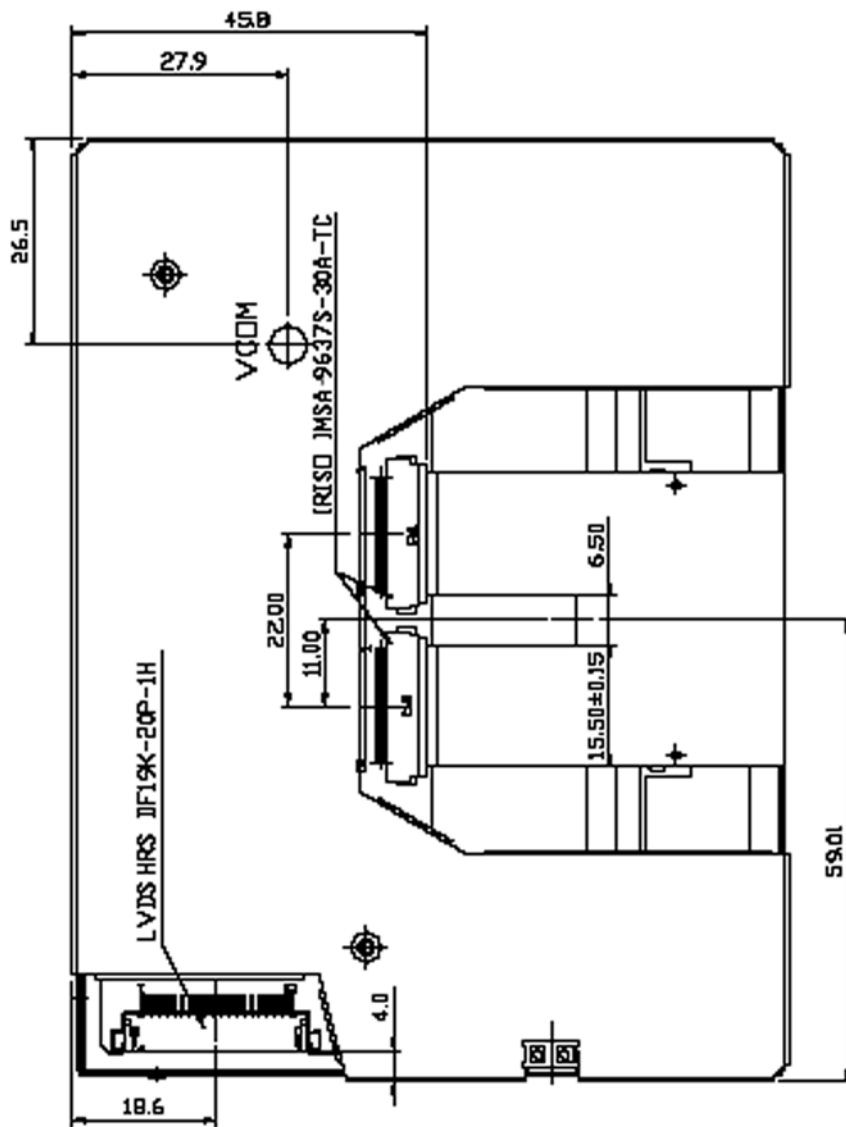

INDEX
 1 GENERAL TOLERANCE: 0.3
 2.3X1 CONECTOR: JST JMS-REVS-1

Display Color and Gray Scale Reference

Color		Input Color Data																	
		Red						Green						Blue					
		R5	R4	R3	R2	R1	R0	G5	G4	G3	G2	G1	G0	B5	B4	B3	B2	B1	B0
Basic Color	Black	0	0	0	0	0	0	0	0	0	0	0	0	0	0	0	0	0	0
	Red (63)	1	1	1	1	1	1	0	0	0	0	0	0	0	0	0	0	0	0
	Green (63)	0	0	0	0	0	0	1	1	1	1	1	1	0	0	0	0	0	0
	Blue (63)	0	0	0	0	0	0	0	0	0	0	0	0	1	1	1	1	1	1
	Cyan	0	0	0	0	0	0	1	1	1	1	1	1	1	1	1	1	1	1
	Magenta	1	1	1	1	1	1	0	0	0	0	0	0	1	1	1	1	1	1
	Yellow	1	1	1	1	1	1	1	1	1	1	1	1	0	0	0	0	0	0
	White	1	1	1	1	1	1	1	1	1	1	1	1	1	1	1	1	1	1
Gray Scale of Red	Red (00)	0	0	0	0	0	0	0	0	0	0	0	0	0	0	0	0	0	0
	Dark	0	0	0	0	0	1	0	0	0	0	0	0	0	0	0	0	0	0
		0	0	0	0	1	0	0	0	0	0	0	0	0	0	0	0	0	0
		:	:	:	:	:	:	:	:	:	:	:	:	:	:	:	:	:	:
	Light	1	1	1	1	0	1	0	0	0	0	0	0	0	0	0	0	0	0
		1	1	1	1	1	0	0	0	0	0	0	0	0	0	0	0	0	0
		1	1	1	1	1	1	0	0	0	0	0	0	0	0	0	0	0	0
Red (63)	1	1	1	1	1	1	0	0	0	0	0	0	0	0	0	0	0	0	
Gray Scale of Green	Green (00)	0	0	0	0	0	0	0	0	0	0	0	0	0	0	0	0	0	0
	Dark	0	0	0	0	0	0	0	0	0	0	0	1	0	0	0	0	0	0
		0	0	0	0	0	0	0	0	0	0	1	0	0	0	0	0	0	0
		:	:	:	:	:	:	:	:	:	:	:	:	:	:	:	:	:	:
	Light	0	0	0	0	0	0	1	1	1	1	0	1	0	0	0	0	0	0
		0	0	0	0	0	0	1	1	1	1	1	0	0	0	0	0	0	0
		0	0	0	0	0	0	1	1	1	1	1	1	0	0	0	0	0	0
Green	0	0	0	0	0	0	1	1	1	1	1	1	0	0	0	0	0	0	
Gray Scale of Blue	Blue (00)	0	0	0	0	0	0	0	0	0	0	0	0	0	0	0	0	0	0
	Dark	0	0	0	0	0	0	0	0	0	0	0	0	0	0	0	0	0	1
		0	0	0	0	0	0	0	0	0	0	0	0	0	0	0	0	1	0
		:	:	:	:	:	:	:	:	:	:	:	:	:	:	:	:	:	:
	Light	0	0	0	0	0	0	0	0	0	0	0	0	1	1	1	1	0	1
		0	0	0	0	0	0	0	0	0	0	0	0	1	1	1	1	1	0
		0	0	0	0	0	0	0	0	0	0	0	0	1	1	1	1	1	1
Blue (63)	0	0	0	0	0	0	0	0	0	0	0	0	1	1	1	1	1	1	